

SCALA 1:1

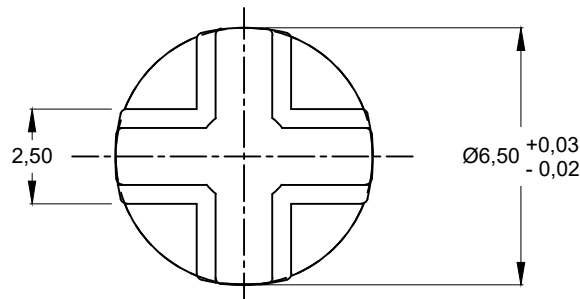

Articolo	IN00221200fe000	Scala 5:1 1:1	
Materiale	FE - FL00002.78FE019	p.s. g.	
Cliente		Data	06/10/2021
Oggetto	INS 2212 fe GREZZO td6,5-gd3,05-3,08 h tot 15,9	N.Disegno	0611 REV.01
Disegnatore	Alessio Lovison	Resp.Tecnico	Silvano Ceron

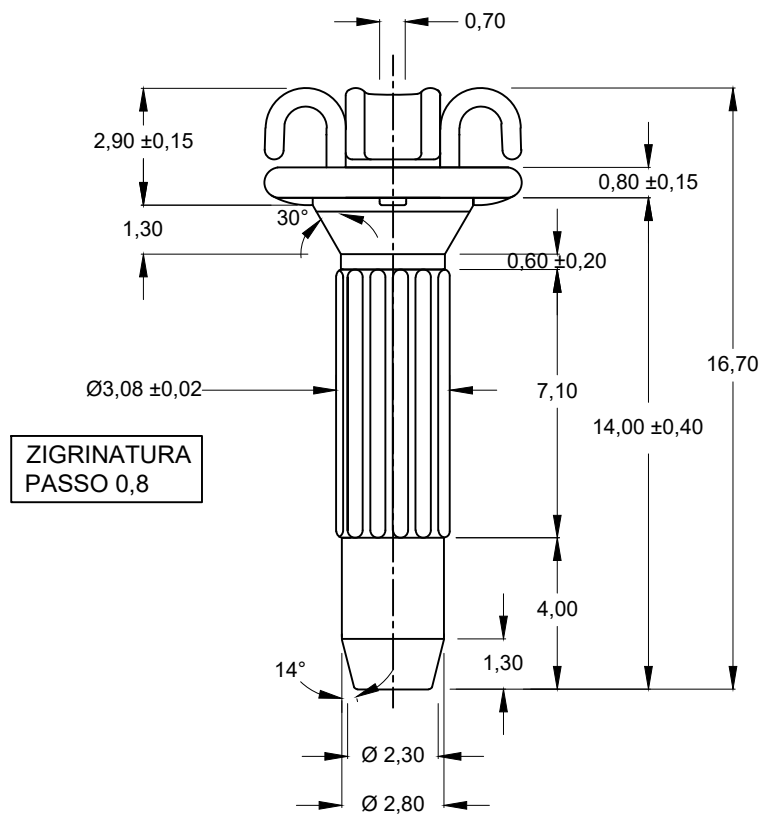

TECNO MINUTERIE GROUP S.R.L.

minuterie metalliche | metal hardware

CAP.SOC. € 100.000 I.V.
 C.F. E P.IVA 01327070288
 35030 SELVAZZANO DENTRO
 LOC. CASELLE - PADOVA (ITALIA)
Sede Legale: VIA MEUCCI, 18
Uff. e Magazzino: VIA MEUCCI, 32

TEL: **+39 049 8977274**
 FAX: **+39 049 8977276**

info@tecnominuterie.com
 www.tecnominuterie.com